



Industrial PC

KIOSK-CM4-215



PN: CS19108RA4215-KK

Content can change at anytime, check our website for latest information of this product.

www.chipsee.com

Contents

KIOSK-CM4-215	3
1. Product Overview	7
2. Ordering Options	8
2.1. Pi [®] CM4 Module	8
2.2. Operating System	8
2.3. Optional Features	9
3. Specifications	10
4. Label Printer	14
5. Barcode Scanner	16
6. Smart Card Reader	17
7. Power Input	17
8. Touch Screen	19
9. Connectivity	20
9.1. RS232/RS485/CAN	20
9.2. GPIO Port	22
9.3. USB Connectors	24
9.4. LAN	26
9.5. WiFi & BT Module	27
9.6. 3G/4G/LTE Module	28
10. TF Card Slot	31
11. Audio Connectors	32
12. PROG Button	33
13. Mechanical Specifications	34
13.1. KIOSK-CM4-215	34
14. Disclaimer	35
15. Technical Support	35

KIOSK-CM4-215

Front View

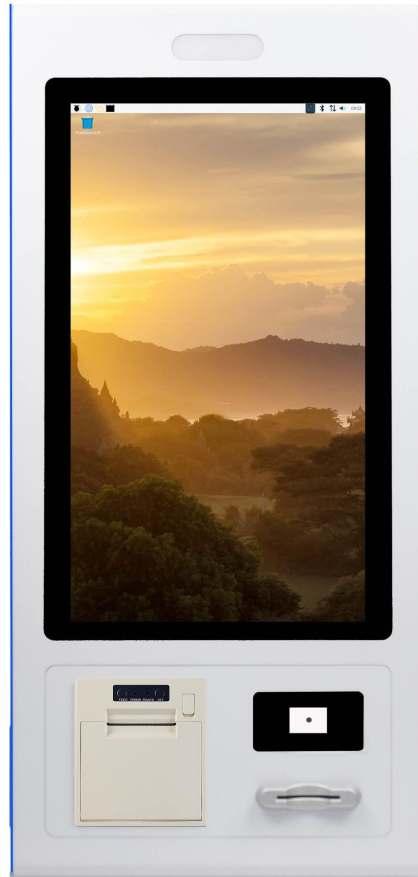

Rear View

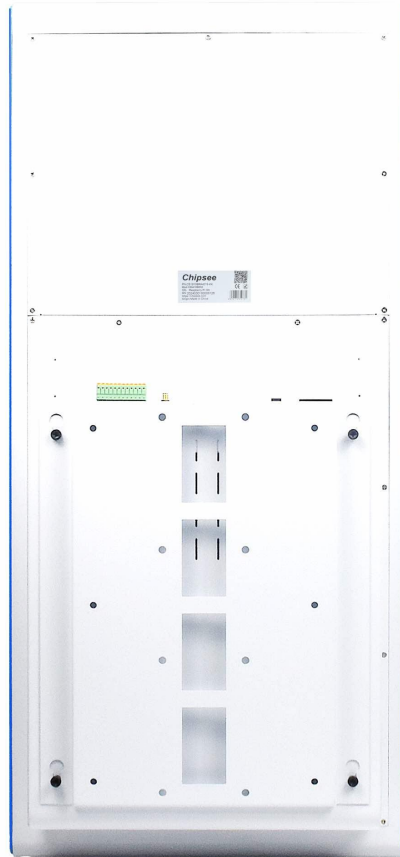

Side View 1



Side View 2



Product Overview

The Cortex[®]-A72 Raspberry Pi[®] series KIOSK-CM4-215 (PN: CS19108RA4215-KK) is a high-quality KIOSK product. It features a 21.5" ten-point(single point in Raspberry Pi OS) capacitive touch screen with a resolution of 1920 x 1080 pixels and brightness of 500 cd/m².

Key Applications

- Ticket machines (e.g., for transportation such as trains, buses, and subways)
- Self-service check-in kiosks at airports
- Informational kiosks in public spaces (e.g., parks, museums, tourist attractions)
- Retail kiosks in shopping malls and retail stores
- Food and beverage kiosks in airports, train stations, and malls
- Self-service payment kiosks at parking lots or toll booths
- Interactive directory kiosks in large buildings or campuses
- Interactive map kiosks in tourist areas or cities
- Self-ordering kiosks in fast-food restaurants or cafes
- Prescription pickup kiosks in pharmacies or healthcare facilities
- Check-in kiosks at hotels or rental car facilities
- Event ticketing kiosks at concert venues or theaters

The KIOSK-CM4-215 industrial Pi Kiosk is based around the powerful Raspberry Pi[®] Compute Module 4, powered by the Quad Cortex[®]-A72 processor with a processor speed of 1.5GHz.

Ordering Options

Chipsee products can be customized during the ordering process. The product will be shipped with the pre-installed factory defaults if no extra requirements are specified. The table in the [Specifications](#) section provides information about the default options bundled with the product.

Note

You can order [KIOSK-CM4-215](#) from the official [Chipsee Store](#) or from your nearest distributor.

Pi[®] CM4 Module

The Pi[®] Compute Module 4 appears in different versions depending on the size of the DDR4 and eMMC.

The KIOSK-CM4-215 industrial Pi Kiosk does not include the CM4 Raspberry Pi[®] module by default. If you would like to purchase it with a CM4, you can select it at the Chipsee store during the ordering process.

Operating System

This product comes with a pre-installed Raspberry Pi OS. Chipsee software engineers have created all the drivers, so every hardware feature is readily available for any standard development tool.

If your project requires a different OS, please [Contact us](#), and we'll make a [customized version](#) that suits your needs.

Optional Features

The KIOSK-CM4-215 industrial Pi Kiosk does not include the 3G/4G/LTE modules by default. These modules are optional and can be selected at the Chipsee store during the ordering process.



Warning

Installation, repair, and maintenance tasks should be performed by trained personnel only. Chipsee does not bear any responsibility for damage caused by inadequate handling of the product.

Specifications

The KIOSK-CM4-215 industrial Pi Kiosk offers a broad range of performance and connectivity options for scalable integration, providing expandability according to future needs. Some of the key features are listed in the table below.

KIOSK-CM4-215	
CPU	Raspberry Pi® CM4; Quad Cortex-A72 at 1.5GHz
Storage	Support for 1 x TF Card ³
RAM	2/4/8 GB, Based on CM4
eMMC	16/32 GB, Based on CM4
Display	21.5" IPS LCD, 1920 x 1080 resolution, brightness 500 cd/m ²
Touch	10-point capacitive touch with 3mm tempered glass, single point touch in Raspberry Pi OS Software
USB	2 x USB 3.0 Host, 1 x USB OTG
LAN	1 x Giga LAN
Audio	3.5mm Audio Out Connector, 2W Speaker Internal
Buzzer	Onboard Buzzer, driven by GPIO
RTC	High accuracy RTC with farad capacitor, can work 1 week after power off (default) . High accuracy RTC with lithium coin battery, can work 3 years after power off <i>(optional)</i> .
RS232	Default to 2 x RS232, up to 4 x RS232
RS485	Default to 2 x RS485 ¹ , these 2 x RS485 can be configured as 2 x RS232
CAN	1 x CAN-BUS
GPIO	8 Channels, 4 Input, 4 Output
I2C	Not Supported
WiFi/BT	Supported but depending on the CM4 selected ²
ZIGBEE	Not supported
HDMI	Not Supported
SATA II	Not Supported
3G/4G/LTE	Supported, not mounted by default
Camera	No
Power Input	100-240V AC 50/60Hz
Current	Less than 1.5A

KIOSK-CM4-215	
Power Consumption	33W Typical, 45W Maximum
Working Temperature	From 0°C to +50°C
OS	Raspberry Pi OS
Dimensions	KIOSK-CM4-215: 826 x 380 x 138mm
Weight	KIOSK-CM4-215: 16.6kg
Mounting Method	Rear Mount

Table 435 Key Features

- 1 The RS485 circuit controls the Input and Output direction automatically, there's no need to control it from within the software.
- 2 The default product without the CM4 does not include a Wi-Fi/BT module. You can include a CM4 that has the Wi-Fi/BT module at the Chipsee store during the ordering process.
- 3 This TF card is designed for storage expansion, as the TF card uses the same pins with WiFi, it can't be used with WiFi at the same time

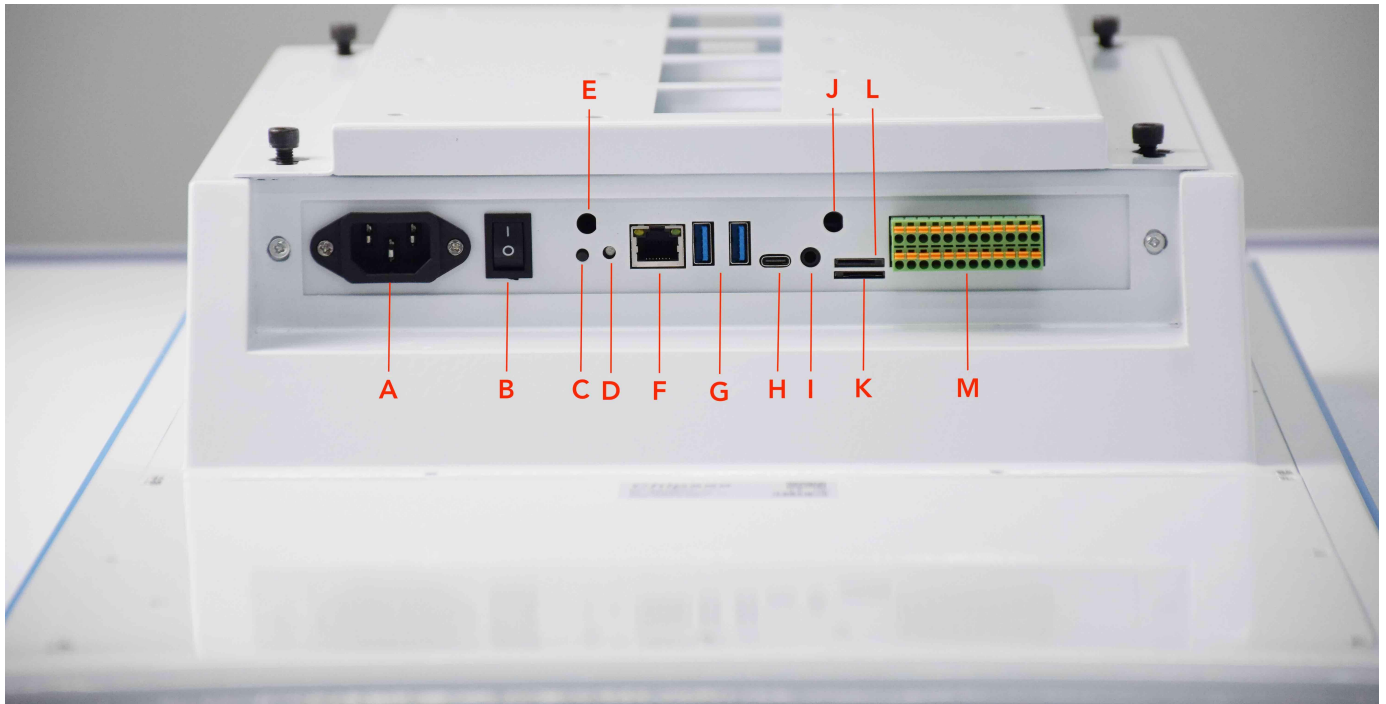

Interfaces of the Product

Label	Interface
A	Power
B	Power Switch
C	PROG Button
D	Status LED
E	4G/LTE Antenna
F	Ethernet
G	USB3.0 HOST
H	USB-C OTG
I	Audio Jack
J	WiFi/Bluetooth Antenna
K	SIM Card Slot
L	TF Card Slot
M	RS232/485 CAN GPIO

Table: Interfaces

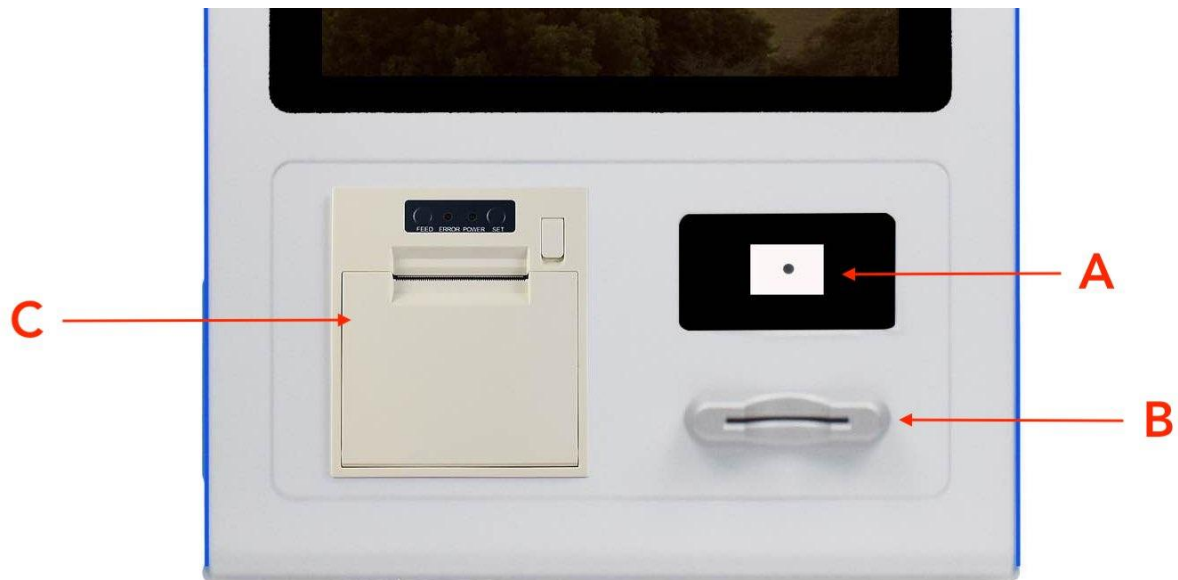

Printer, Barcode Scanner, Smart Card Reader

Label	Interface	Model
A	Barcode Scanner	LR1008 1D and 2D barcode scanner
B	Smart Card Reader	RCR-2913 hybrid dual interface (contact and contactless) smart card reader
C	Label Printer	SPRT SP-RMD17 58mm thermal label printer

Table: Printer, Barcode Scanner, Smart Card Reader

Label Printer

The KIOSK-CM4-215 industrial Pi Kiosk features a thermal label printer (SPRT SP-RMD17).



Thermal Label Printer

Printing Performance

1. Printing Method: Thermal Printing
2. Paper Width: 57.5±0.5mm
3. Printing Density: 8 dots/mm, 384 dots/line
4. Printing Speed: 70mm/second (maximum)
5. Reliability: Printhead Lifespan - 60km

Usage Conditions:

- a. Print 12 × 24 Western characters, 50 lines per print, intermittently repeat printing
- b. Simultaneous printing of each dot line does not exceed 25%, no more than 11 vertical repetitions of the same point for each character line
- c. Use specified thermal paper

6. Effective Printing Width: 48mm

Printing Paper

1. Thermal Paper Roll Model:
 - a. TF50KS-E (Japan Paper Co. Ltd.)

b. AF50KS-E (Jujo Thermal)

2. Thermal Paper Roll:

a. Paper Width: 57.5±0.5mm

b. Outer Diameter: φ 60mm (maximum)

c. Inner Diameter: φ 13mm±0.3 (minimum)

d. Paper Thickness: 0.06mm~0.08mm

Printer Control Commands

1. Character Printing Commands: Supports printing of ANK characters, custom characters, with adjustable character line spacing.
2. Dot Matrix Printing Commands: Supports printing of dot matrix graphics with different densities and downloaded graphics.
3. GS Barcode Printing Commands: Supports printing of UPC-A, UPC-E, EAN-13, EAN-8, CODE39, ITF25, CODABAR, CODE93, CODE128 barcodes.

Barcode Scanner

The KIOSK-CM4-215 industrial Pi Kiosk features a barcode scanner:



Barcode Scanner (Customized)

The scanner module utilizes a specialized image processing chip for barcode recognition, enabling fast and stable code reading even in complex environments.

It supports reading one-dimensional(1D) and two-dimensional(2D) codes on various media such as paper, screens, and plastics.

Triggering Methods: Automatic sensing, continuous reading, command triggering

Camera: 1.3MP 720p

Scanning Angle: Tilt angle $\pm 85^\circ$, rotation 360°

Supported Barcode Types:

- 1D codes: UPC-A, UPC-E, EAN-13, ISBN10, ISBN13, EAN-8, CODE39, CODE 11, CODE 93, CODE128, INTERLEAVED25, INDUSTRIAL25, MATRIX25, S25, CODE 32, TRIOPTIC39, GS1_128, CODABAR, MSI, China Post code, TELEPEN, RSS, GS1_DATABAR, GS1_DATABAR_LIM, GS1_DATABAR_EXP;
- 2D codes: QR, MICROQR, PDF417, Data Matrix

Reading Distance: 5cm ~ 20cm

Smart Card Reader

The KIOSK-CM4-215 industrial Pi Kiosk features an RCR-2913 hybrid dual interface (contact and contactless) smart card reader

The RCR-2913 smart card reader supports hybrid dual interface contact(ISO-7816) and contactless(ISO-14443) card reading.

It is a powerful and efficient dual interface smart card reader that can be used to access ISO 7816 MCU cards, MIFARE® cards and ISO 14443 Type A and B contactless cards.



Smart Card Reader (Contact and Contactless)

Power Input

The KIOSK-CM4-215 industrial Pi Kiosk power input is 100-240V AC 50/60Hz. As shown in the figure below.

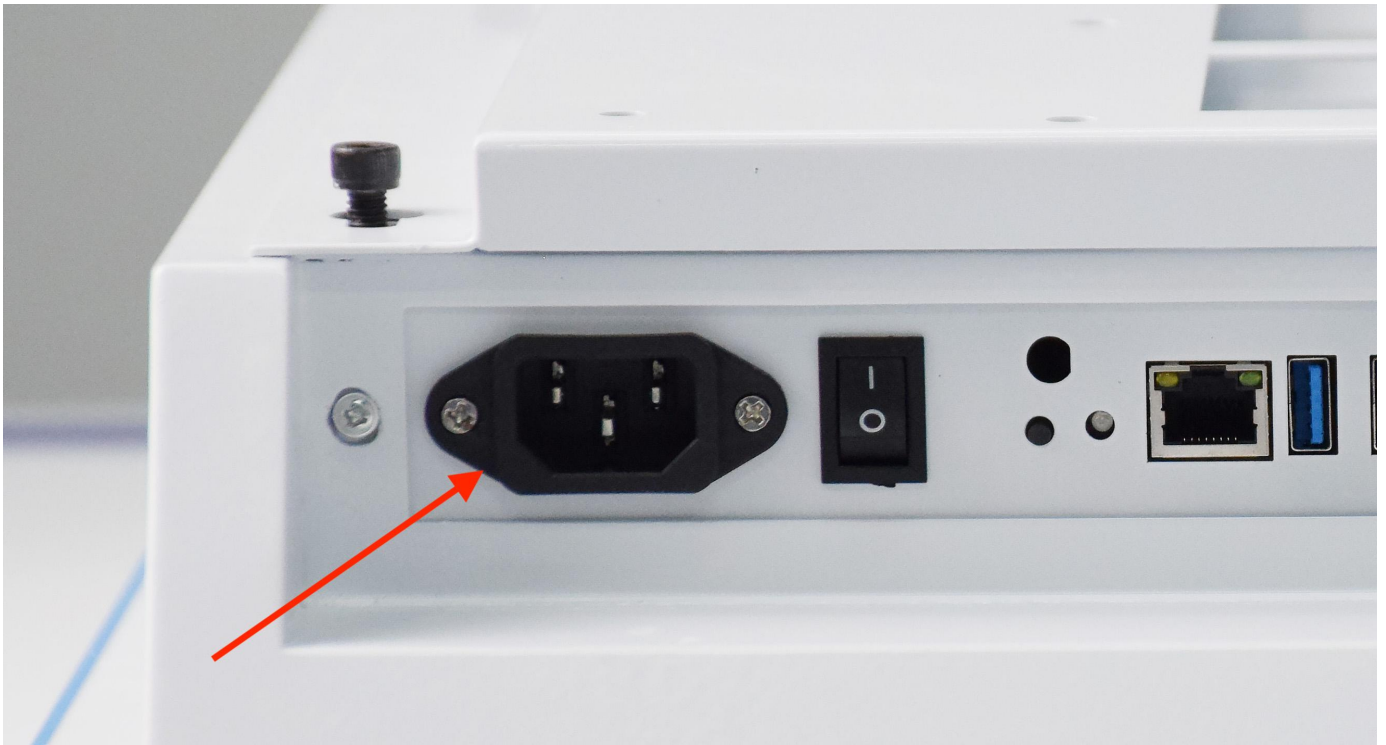

Power Input

Touch Screen

The KIOSK-CM4-215 industrial Pi Kiosk uses a 10-point capacitive touch with 3mm tempered glass, single point touch in Raspberry Pi OS Software screen. However, the Raspberry Pi OS supports only One-Point touch.

The figure below shows the capacitive touch screen connected to the motherboard via the USB connector.

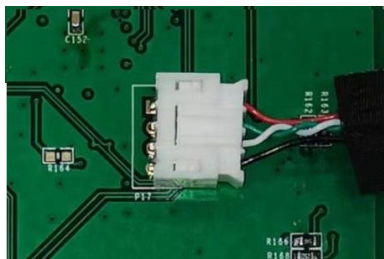

Capacitive Touch Connector

Connectivity

There are many connectivity options available on the KIOSK-CM4-215 industrial Pi PC. It has 2 x USB 3.0 Host, 1 x USB OTG, 1 x Giga LAN (RJ45) Ethernet connector supporting up to 1 Gbps, and 4 x UART and 1 x CAN terminals (RS232/RS485/CAN).

RS232/RS485/CAN

The serial communication interfaces (RS485, RS232, and CAN) are routed to a phoenix terminal, as illustrated in the figure below.

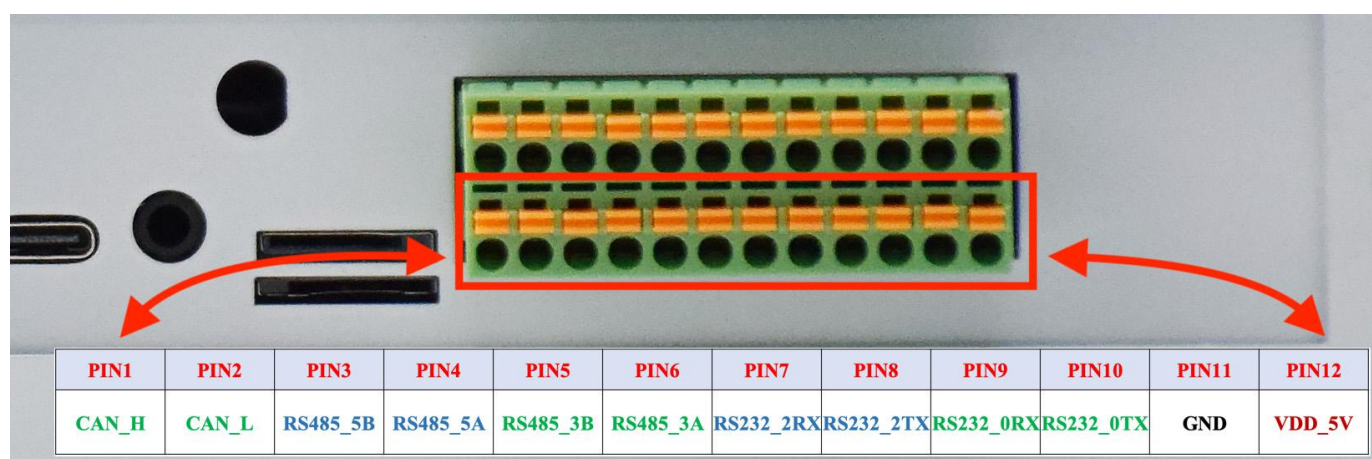

RS232-RS485-CAN on the KIOSK-CM4-215 Industrial PC

⚠ Attention

1. RS485_3 and RS485_5 can control the input and output direction automatically. There's no need to control it from within the software.
2. The 120Ω match resistor for RS485 is **already** mounted by default.
3. The 120Ω match resistor for CAN is **NOT** mounted by default. Be sure to mount the match resistor when testing CAN.
4. The 2 x RS485 can be configured to 2 x RS232, if you want a custom configuration, you can contact us when placing an order.

The table below offers more detailed description of every pin and its definition:

RS232 / RS485 / CAN Pin Definition:		
Pin Number	Definition	Description
Pin 1	CAN_H	CAN BUS "H" signal
Pin 2	CAN_L	CAN BUS "L" signal
Pin 3	RS485_5-	CPU UART5, RS485 -(B) signal
Pin 4	RS485_5+	CPU UART5, RS485 +(A) signal

RS232 / RS485 / CAN Pin Definition:		
Pin 5	RS485_3-	CPU UART3, RS485 -(B) signal
Pin 6	RS485_3+	CPU UART3, RS485 +(A) signal
Pin 7	RS232_2_RXD	CPU UART2, RS232 RXD signal
Pin 8	RS232_2_TXD	CPU UART2, RS232 TXD signal
Pin 9	RS232_0_RXD	CPU UART0, RS232 RXD signal
Pin 10	RS232_0_TXD	CPU UART0, RS232 TXD signal
Pin 11	GND	System Ground
Pin 12	+5V	System +5V Power Output, No more than 1A Current output

Table 436 Connectivity Section

GPIO Port

The KIOSK-CM4-215 industrial Pi Kiosk has a **phoenix connector**, as shown in the figure below. The table below gives details about the definition of every Pin.

Attention

1. In order to use the Isolated Output, you need to add an external Isolated Power to the VDD_ISO and GND_ISO. The power voltage should not exceed 24V.
2. The output current can achieve 500mA for every channel, but it also depends on the isolated power that is connected.
3. In order to use the Isolated Input, you need to add a signal to the ISO_InputX and GND_ISO. A 2.4KΩ resistor, as R6, has been added to limit the input current, as shown in the figure below. This resistor should work well for the 5-24V input signal. If your input signal is less than 5V, please change this input resistor. The reduced schematic is for reference purpose, if you need the precise resistor schematic, please contact us.

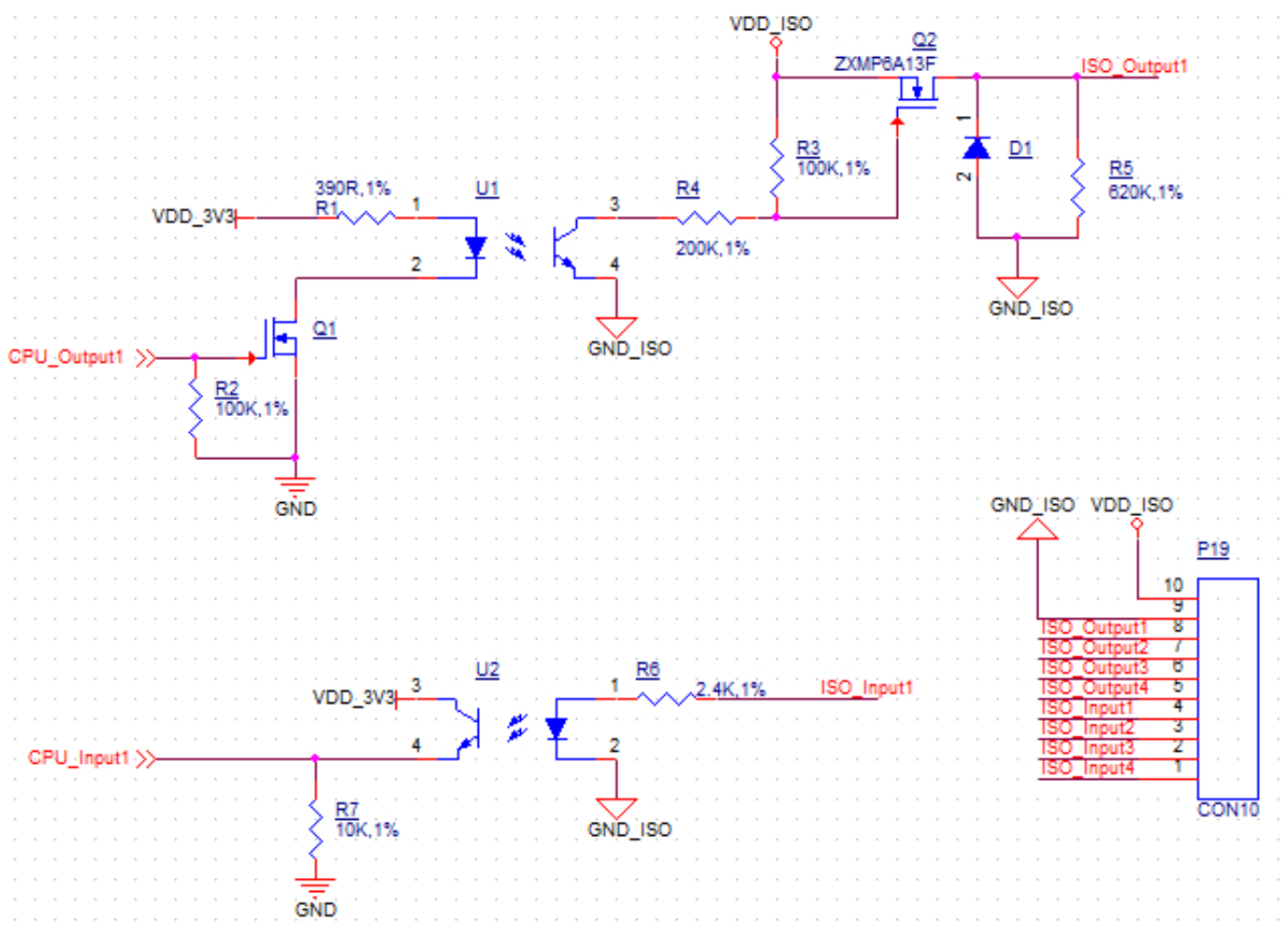

Isolated GPIO reduced schematic

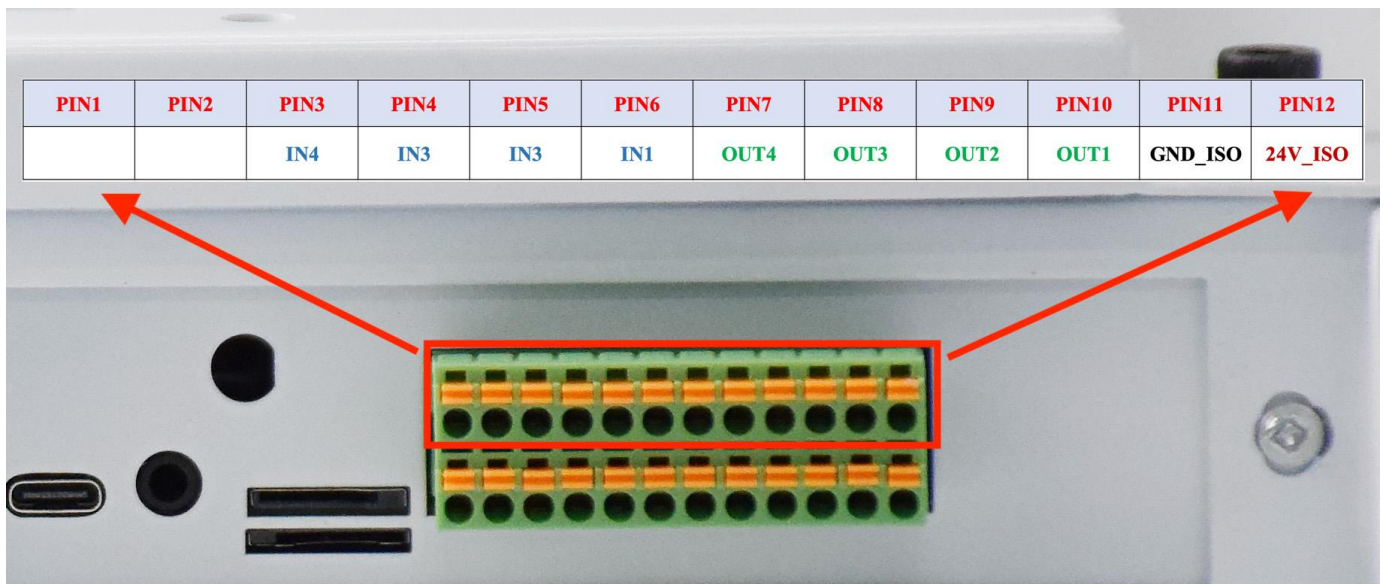

GPIO Connector

GPIO Connector Pin Definition:		
Pin Number	Definition	Description
Pin 12	24V_ISO	Isolated Power +24V Input
Pin 11	GND_ISO	Isolated Ground
Pin 10	OUT1	Isolated Output 1
Pin 9	OUT2	Isolated Output 2
Pin 8	OUT3	Isolated Output 3
Pin 7	OUT4	Isolated Output 4
Pin 6	IN1	Isolated Input 1
Pin 5	IN2	Isolated Input 2
Pin 4	IN3	Isolated Input 3
Pin 3	IN4	Isolated Input 4

Table 437 GPIO Connector Pin-out

USB Connectors

There are 2 x USB 3.0 Host, 1 x USB OTG onboard, as shown in the figure below.

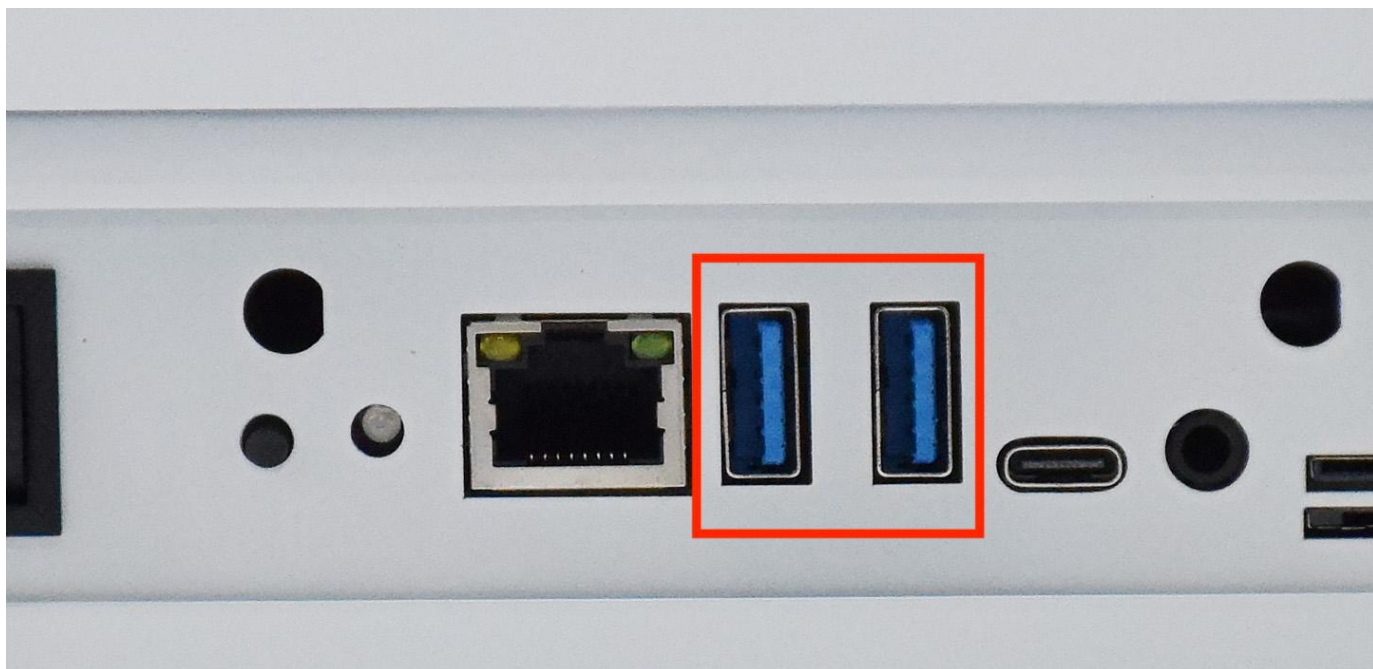

USB HOST Connectors

⚠ Attention

1. These two USB host connectors can drive 500mA for each channel at most.

The product has one USB Type-C OTG connector that works as a slave by default. You can use it to establish a connection with the host PC and for downloading the system to the eMMC of CM4 module.



USB Type-C OTG Connector

 **Warning**

1. Be careful not to touch surrounding electronic components accidentally while plugging in USB devices into the embedded Industrial PC version.
2. Remember to unplug the Type-C cable after flashing OS, otherwise the USB hosts won't work.

LAN

The 1 x Giga LAN provides Ethernet connectivity over standardized Ethernet cables as shown in the figure below. The integrated Ethernet interface supports up to 1 Gbps data throughput. These Giga LAN signals come from the CM4 module directly.

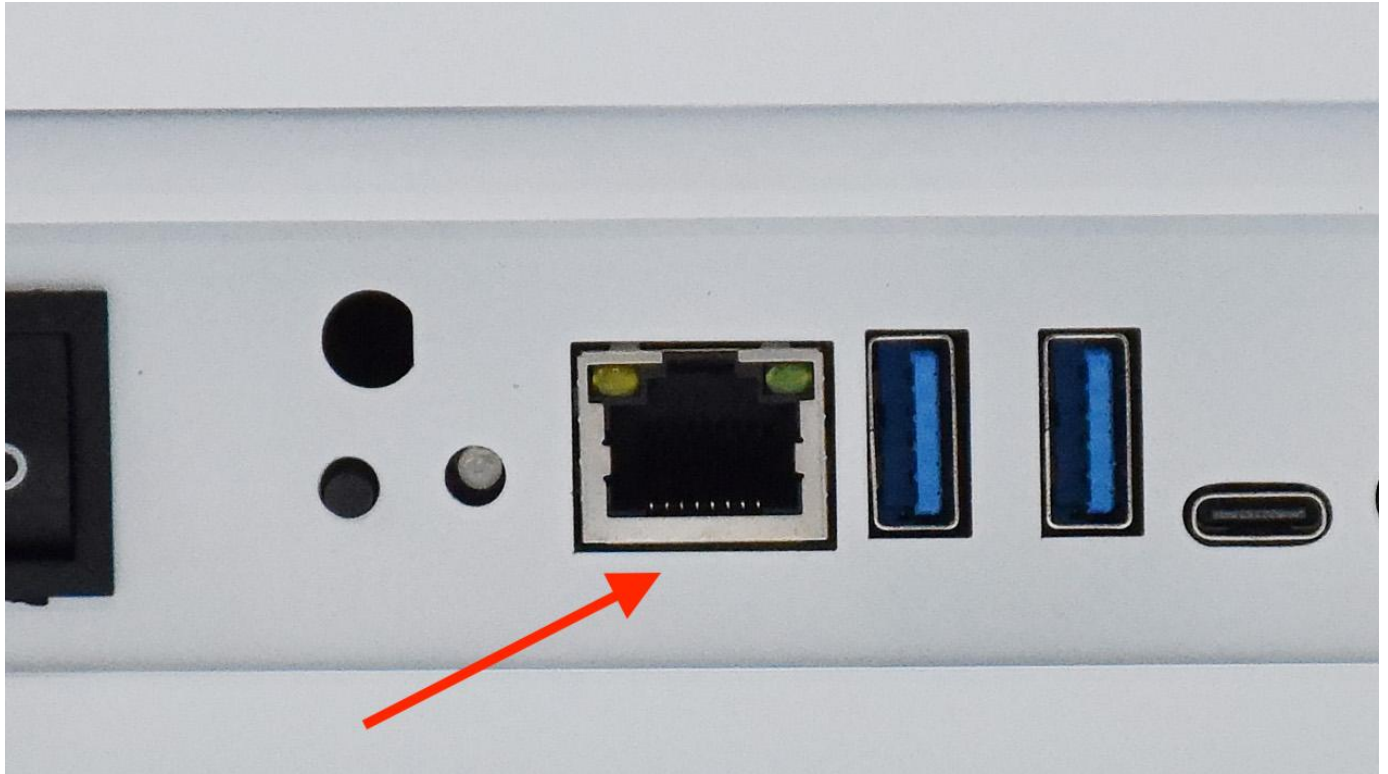

RJ45 LAN Connector

Note

Use CAT5 or better cables to achieve full data throughput over maximum distance defined by the 1000BASE-T standard (100m).

WiFi & BT Module

The default KIOSK-CM4-215 without the CM4 does not include a Wi-Fi/BT module.

If you buy a CM4 that has the Wi-Fi/BT module, the product will have Wi-Fi/BT feature.

By default the kiosk doesn't ship with WiFi antenna SMA, nor is there a drill hole. But if you buy the CM4 with Wi-Fi/BT module from us or contact us when placing an order, we can drill hole on the kiosk and install the antenna SMA for you.

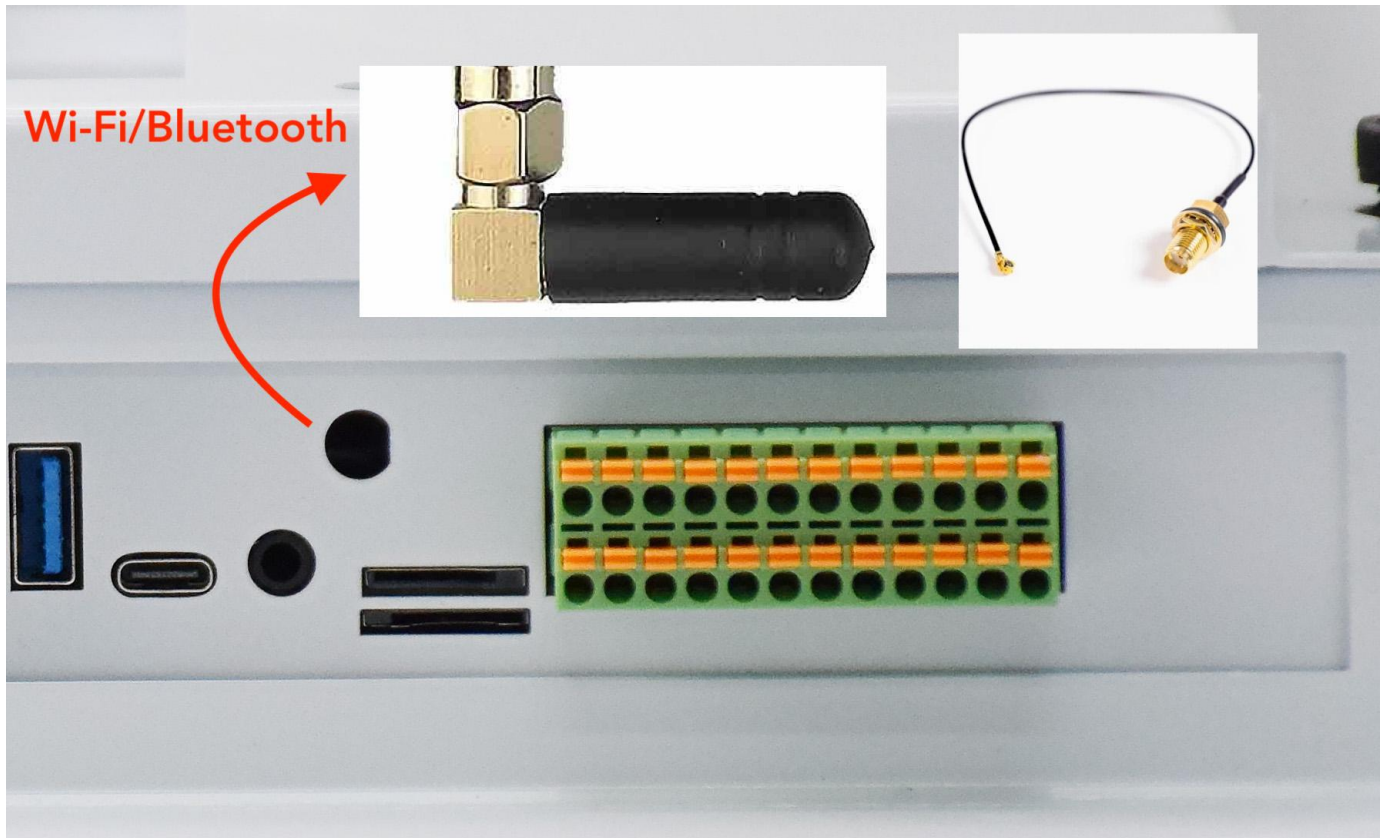

WiFi+BT Antenna

⚠ Attention

The product does not come shipped with the Wi-Fi/BT module by default.

3G/4G/LTE Module

The KIOSK-CM4-215 industrial Pi Kiosk is equipped with a **mini-PCle connector** that can connect to a 3G/4G/LTE module. The customer will also need a SIM Card Holder and a 3G/4G/LTE antenna to ensure 3G/4G/LTE works on the KIOSK-CM4-215. SIM card does **NOT** support hot plug. **Power off** before inserting or removing SIM card.

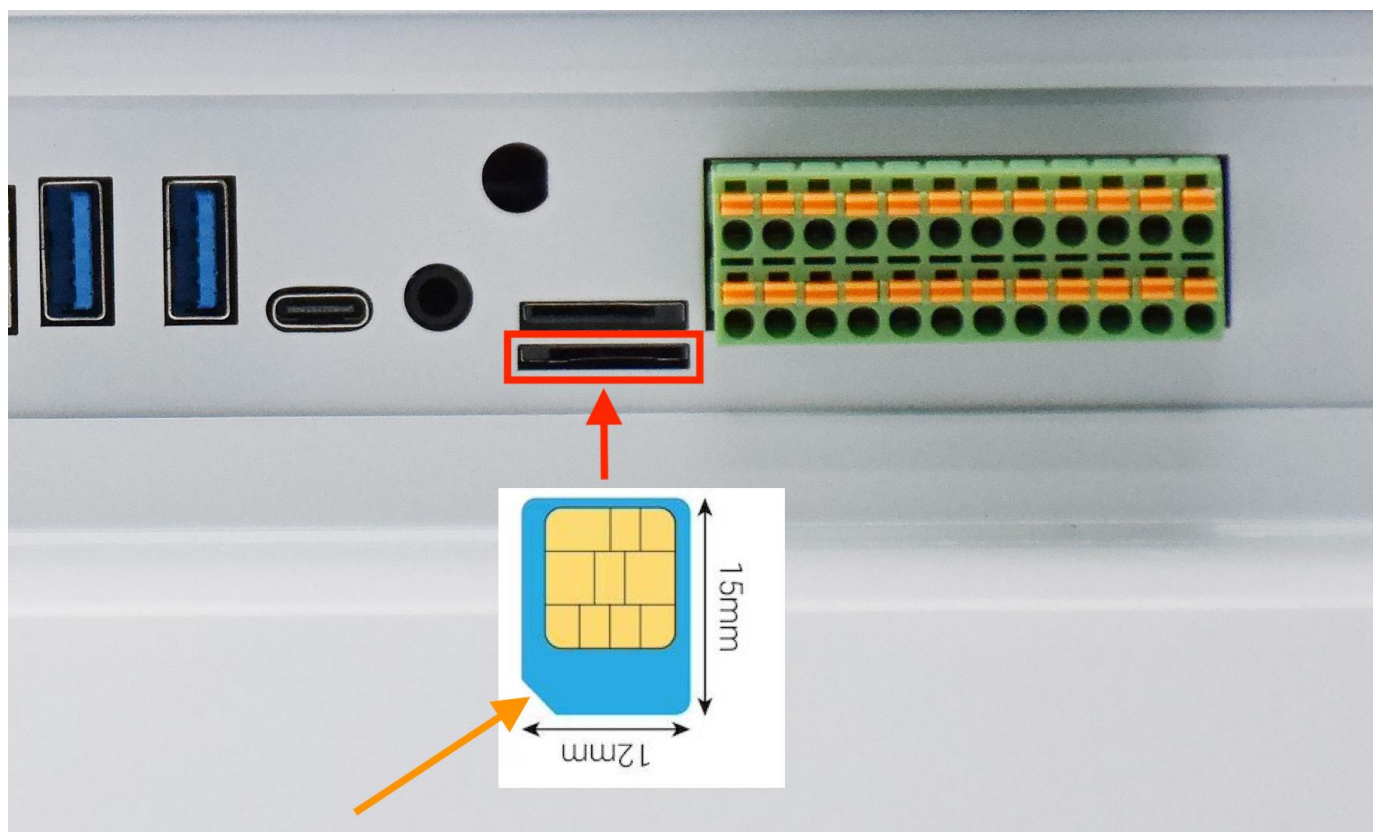

SIM Card Direction



Figure 989: 3G/4G/LTE Module



Figure 990: SIM Card Holder and 3G/4G/LTE Antenna

⚠ Attention

The product does not come shipped with the 3G/4G/LTE module by default. If you need to use 3G/4G/LTE, you can contact us when placing an order, we can install the necessary hardware for you.

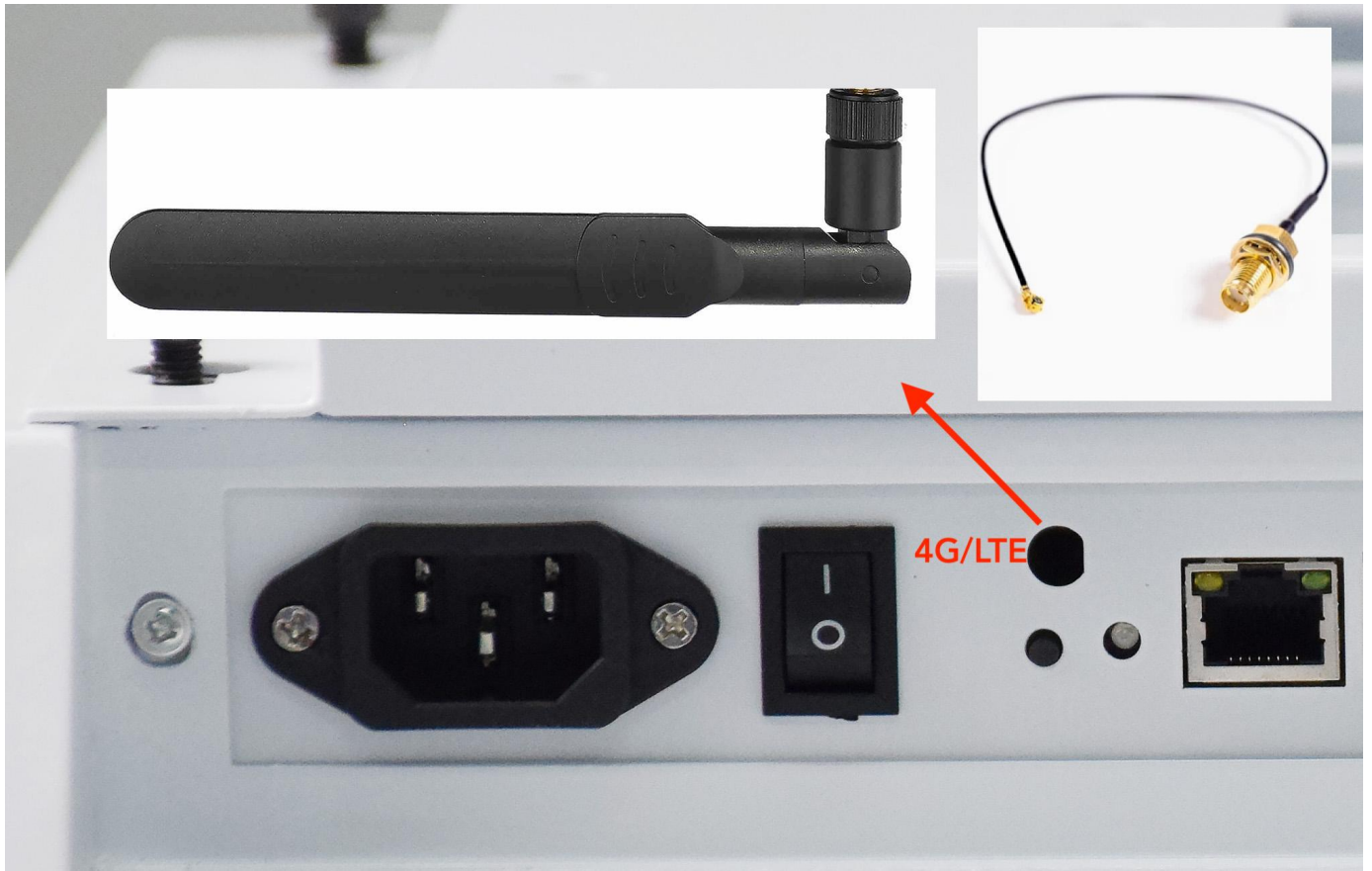

4G Antenna

TF Card Slot

The KIOSK-CM4-215 industrial Pi Kiosk features 1 x **TF Card (micro SD) slot**. A slot can address up to 128GB of memory.

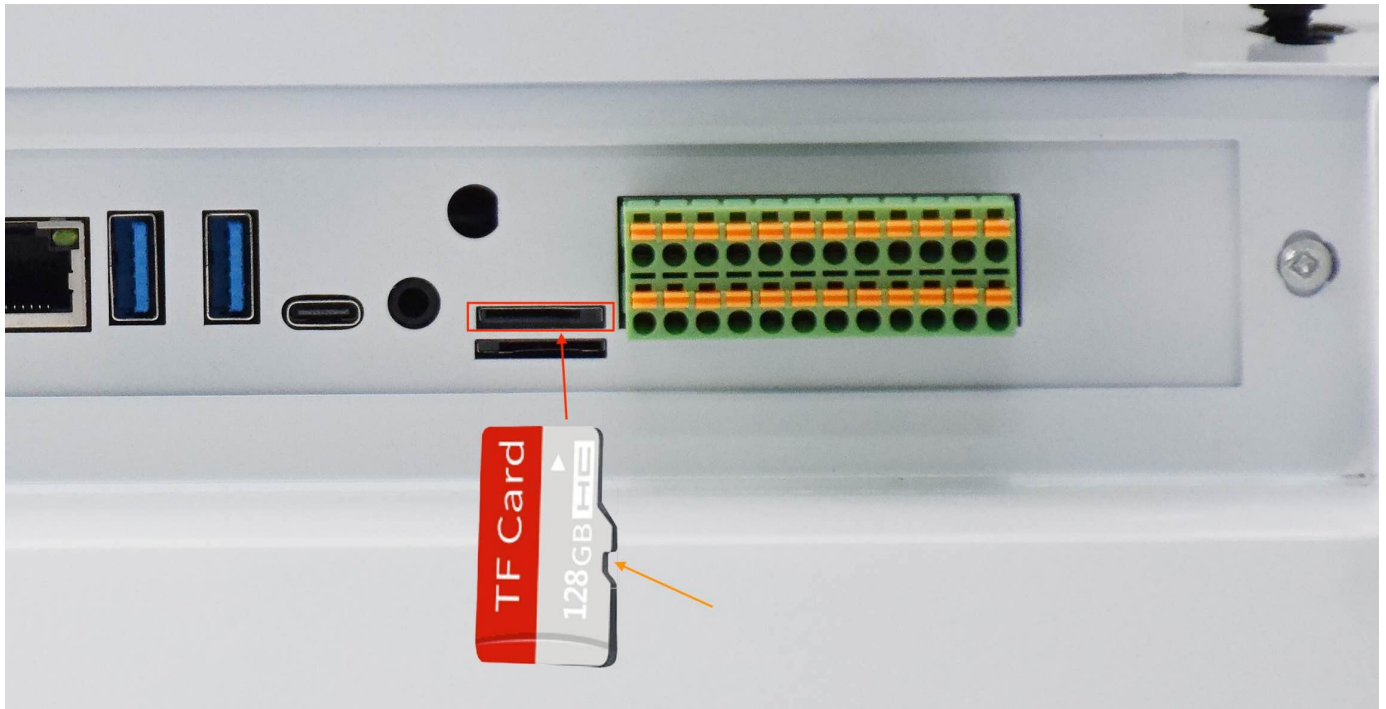

TF (micro SD) Card Slot

⚠ Attention

1. The SD is used for memory extension. It can't be used for system boot-up.
2. This storage extension SD uses the same pins as WiFi on CM4. SD storage and WiFi **can't** be used at the same time.
3. The product does not come shipped with the TF card by default.

Audio Connectors

The KIOSK-CM4-215 industrial Pi Kiosk features some audio peripherals. It has 1 x **3.5mm audio output jack**.

Also, the KIOSK-CM4-215 industrial Pi PC has a miniature 2W internal speaker for audio reproduction, as well as a small buzzer for alarm/notification sounds.

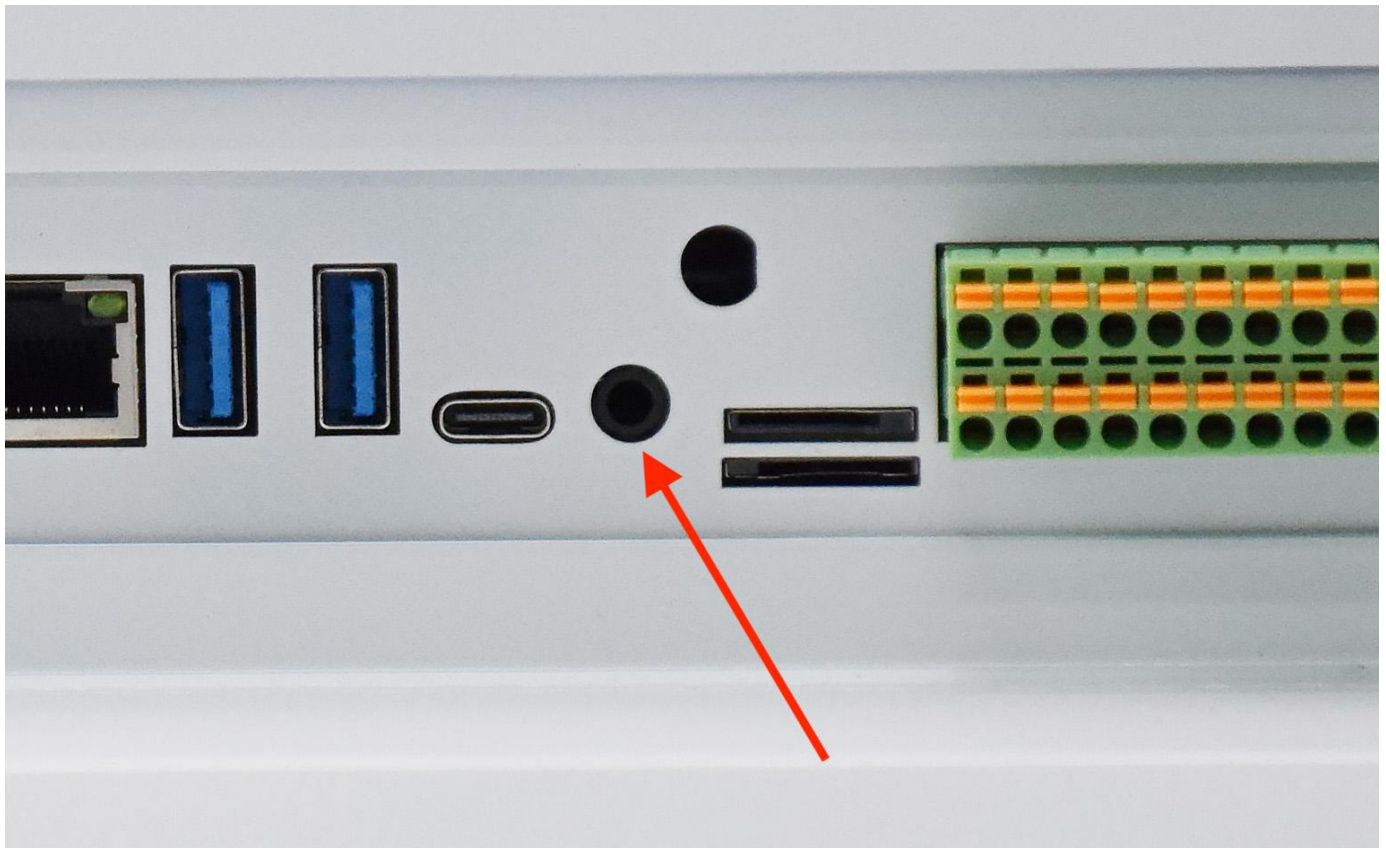

Audio Connector

Attention

By plugging in the headphone cable, the internal speaker will be disabled automatically.

PROG Button

The KIOSK-CM4-215 industrial Pi Kiosk has one button for entering usb download mode, as shown in the figure below.

When booting **with** the button being pressed, the Raspberry Pi will boot from the USB connector. You can use this feature to download the OS software to the internal eMMC. When booting **without pressing** the button, the Raspberry Pi will boot from the internal eMMC.

There is no need to press the button during regular operation. However, if you need to reinstall the OS, please refer to the detailed information on how to reflash the OS from the [Software Documentation](#).



PROG Button

Mechanical Specifications

KIOSK-CM4-215

For KIOSK-CM4-215, the outer mechanical dimensions are 826 x 380 x 138mm (W x L x H).

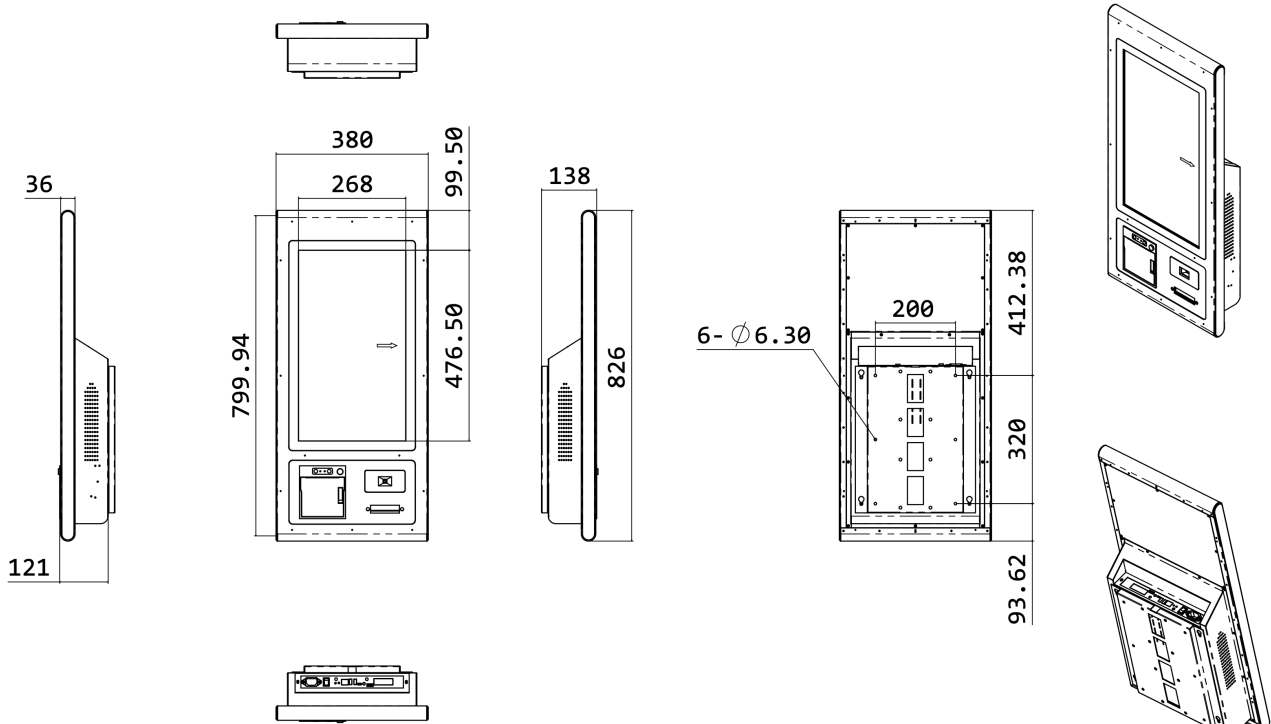

Technical Drawing

Disclaimer

This document is provided strictly for informational purposes. Its contents are subject to change without notice. Chipsee assumes no responsibility for any errors that may occur in this document. Furthermore, Chipsee reserves the right to alter the hardware, software, and/or specifications set forth herein at any time without prior notice and undertakes no obligation to update the information contained in this document.

While every effort has been made to ensure the accuracy of the information contained herein, this document is not guaranteed to be error-free. Further, it does not offer any warranties or conditions, whether expressed orally or implied in law, including implied warranties and conditions of merchantability or fitness for a particular purpose. We specifically disclaim any liability with respect to this document, and no contractual obligations are formed either directly or indirectly by this document.

Despite our best efforts to maintain the accuracy of the information in this document, we assume no responsibility for errors or omissions, nor for damages resulting from the use of the information herein. Please note that Chipsee products are not authorized for use as critical components in life support devices or systems.

Technical Support

If you encounter any difficulties or have questions related to this document, we encourage you to refer to our other documentation for potential solutions. If you cannot find the solution you're looking for, feel free to contact us. Please email Chipsee Technical Support at support@chipsee.com, providing all relevant information. We value your queries and suggestions and are committed to providing you with the assistance you require.